



**3.3V, 1.5GHz ÷1/÷2 DIFFERENTIAL  
LVECL/LVPECL PROGRAMMABLE CLOCK  
GENERATOR AND 1:15 FANOUT BUFFER**

**Precision Edge®  
SY100E222L**

**FEATURES**

- Four programmable output banks and 15 total LVPECL-compatible differential outputs
- Pin-compatible, plug-in replacement to MC100LVE222FA
- $f_{MAX}$  clock = 1.5GHz
- 50ps output-to-output skew
- Four output banks with independent ÷1, ÷2 frequency control
- 100k compatible I/O
- Power supply 3.3V ±10%
- -40°C to +85°C temperature range
- Available in 52-pin LQFP package

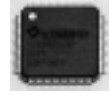

Precision Edge®

**DESCRIPTION**

The SY100E222L is a low-skew, low-jitter device capable of receiving a high-speed LVECL/LVPECL input in either a single-ended or differential configuration. For single-ended configurations, a  $V_{BB}$  output reference is supplied by the SY100E222L. A 2:1 input multiplexer selects from two differential input pairs by means of the CLK\_SEL input select.

The internal programmable divider for each of the four banks generates a ÷1 or ÷2 frequency of the selected input. The ÷1/÷2 divider outputs can be asynchronously synchronized with the master reset (MR) input so that the outputs will start out in a known state.

The 15 total outputs are partitioned into four independently selected output banks in a 2/3/4/6 fanout configuration. Each of the four banks can independently select the ÷1 or ÷2 output frequency by means of the four separate frequency select pins (FSELA-FSELD) inputs.

The SY100E222L is pin-for-pin compatible with the MC100LVE222FA device.

The SY100E222L is part of a Micrel's Precision Edge® product family. For other integrated clock divider plus fanout buffer options, consider Micrel's SY89200 family.

All support documentation can be found on Micrel's web site at: [www.micrel.com](http://www.micrel.com).

**FUNCTIONAL BLOCK DIAGRAM**

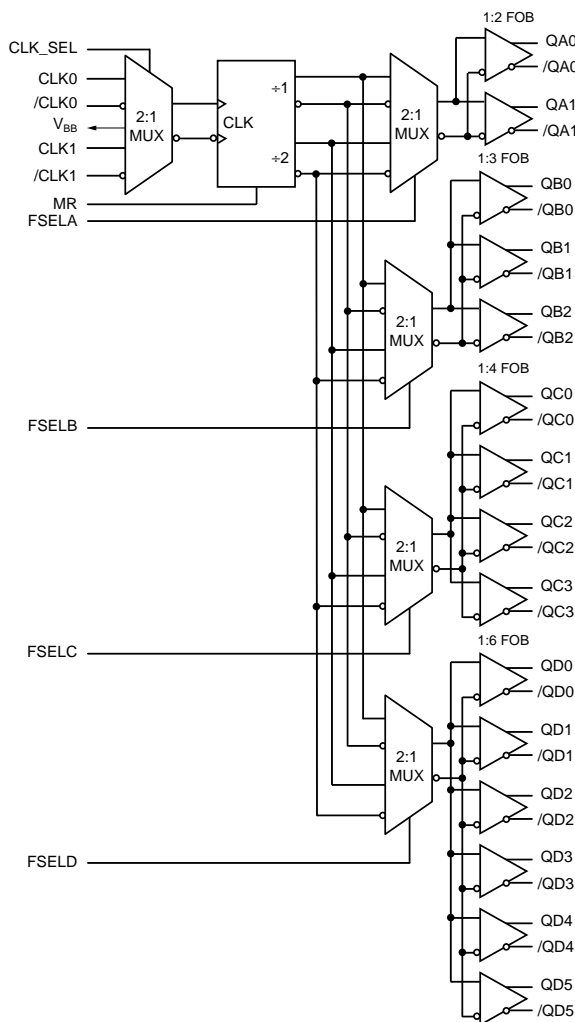

**CROSS REFERENCE TABLE**

Micrel Part Number	ON Semiconductor
SY100E222LTI	MC100LVE222FA
SY100E222LTI TR	MC100LVE222FAR2

**APPLICATIONS**

- SONET/SDH channel applications
- Fibre Channel multi-channel applications
- Gigabit Ethernet multi-channel applications

Precision Edge is a registered trademark of Micrel, Inc.

**PACKAGE/ORDERING INFORMATION**

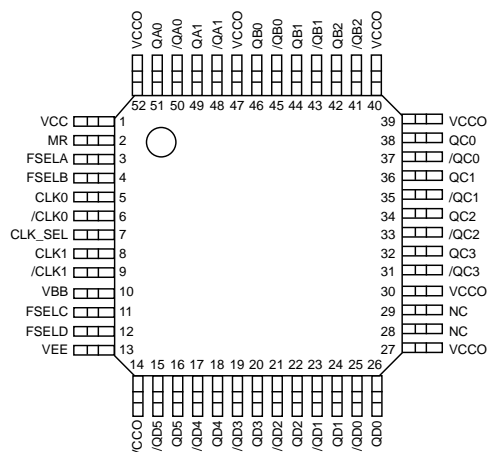

**52-Pin LQFP (LQFP-52)**

**Ordering Information<sup>(1)</sup>**

Part Number	Package Type	Operating Range	Package Marking	Lead Finish
SY100E222LTI	LQFP-52	Industrial	SY100E222L	Sn-Pb
SY100E222LTITR <sup>(2)</sup>	LQFP-52	Industrial	SY100E222L	Sn-Pb
SY100E222LTY <sup>(3)</sup>	LQFP-52	Industrial	SY100E222L with Pb-Free bar-line indicator	Matte-Sn Pb-Free
SY100E222LTYTR <sup>(2, 3)</sup>	LQFP-52	Industrial	SY100E222L with Pb-Free bar-line indicator	Matte-Sn Pb-Free

**Notes:**

1. Contact factory for die availability. Dice are guaranteed at T<sub>A</sub> = 25°C, DC Electricals only.
2. Tape and Reel.
3. Pb-Free package is recommended for new designs.

**PIN DESCRIPTION**

Pin Number	Pin Name	Pin Function
2	MR	100k ECL compatible: Master reset function resets all outputs to a differential LOW when MR pin goes HIGH.
5, 6, 8, 9	CLK0, /CLK0, CLK1, /CLK1	Differential inputs: These input pairs are the differential signal inputs to the device. Inputs accept 100k LVPECL/LVECL levels.
7	CLK_SEL	100k ECL compatible input select. LOW = CLK0, HIGH= CLK1.
3	FSELA	100k ECL compatible bank A output select. LOW: QA0-QA1 = +1, HIGH: QA0-QA1 = +2.
4	FSELB	100k ECL compatible bank B output select. LOW: QB0-QB2 = +1, HIGH: QB0-QB2 = +2.
11	FSELC	100k ECL compatible bank C output select. LOW: QC0-QC3 = +1, HIGH: QC0-QC3 = +2.
12	FSELD	100k ECL compatible bank D output select. LOW: QD0-QD5 = +1, HIGH: QD0-QD5 = +2.
51, 49, 50, 48	QA0 – QA1, /QA0 – /QA1	Bank A 100k differential output pairs controlled by FSELA. FSELA: LOW, QA = +1, HIGH, QA = +2.
46, 44, 42, 45, 43, 41	QB0 – QB2, /QB0 – /QB2	Bank B 100k differential output pairs controlled by FSELB. FSELB: LOW, QB = +1, HIGH, QB = +2.
38, 36, 34, 32, 37, 35, 33, 31	QC0 – QC3, /QC0 – /QC3	Bank C 100k differential output pairs controlled by FSELC. FSELC: LOW, QC = +1, HIGH, QC = +2.
26, 24, 22, 20, 18, 16, 25, 23, 21, 19, 17, 15	QD0 – QD5, /QD0 – /QD5	Bank D 100k differential output pairs controlled by FSELD. FSELD: LOW, QD = +1, HIGH, QD = +2.
1	VCC	Positive power supply: Bypass with 0.1µF    0.01µF low ESR capacitors.
14, 27, 30, 39, 40, 47, 52	VCCO	Positive power supply for output buffers. Bypass with 0.1µF    0.01µF low ESR capacitors.
13	VEE	Negative power supply. For LVPECL systems, VEE is GND.
10	VBB	Reference voltage.
28, 29	NC	No connect: Not internally connected (unused pins).

### Absolute Maximum Ratings<sup>(1)</sup>

Supply Voltage ( $V_{CC}$ )	-0.5V to + 4.0V
Input Voltage ( $V_{IN}$ )	-0.5V to $V_{CC}$
Termination Current <sup>(3)</sup>	
Source or sink current on $V_{BB}$ ( $I_{BB}$ )	$\pm 0.5$ mA
DC Output Current	
LVPECL Outputs	-50mA
Lead Temperature (soldering, 20 sec.)	+260°C
Storage Temperature ( $T_S$ )	-65°C to +150°C

### Operating Ratings<sup>(2)</sup>

Supply Voltage ( $V_{CC}$ )	+3.0V to +3.6V
Ambient Temperature ( $T_A$ )	-40°C to +85°C
Package Thermal Resistance	
LQFP ( $\theta_{JA}$ )	
Still-Air	70°C/W
500lfpm	48°C/W

## DC ELECTRICAL CHARACTERISTICS<sup>(4)</sup>

Symbol	Parameter	Condition	Min	Typ	Max	Units
$I_{CC}$	Power Supply Current	Max. $V_{CC}$ all inputs and outputs OPEN		122	139	mA

## LVPECL DC ELECTRICAL CHARACTERISTICS<sup>(4, 5)</sup>

$V_{CC} = +3.3V \pm 0.3V$ ;  $V_{EE} = 0V$ ;  $T_A = -40^\circ C$  to  $+85^\circ C$ , typicals are  $T_A = 25^\circ C$ .

Symbol	Parameter	Condition	Min	Typ	Max	Units
$V_{OH}$	Output High Voltage	$R_L = 50\Omega$ to $V_{CC}-2V$	2215	2345	2420	mV
$V_{OL}$	Output Low Voltage	$R_L = 50\Omega$ to $V_{CC}-2V$	1470	1595	1680	mV
$V_{IH}$	Input High Voltage		2135		2420	mV
$V_{IL}$	Input Low Voltage		1490		1825	mV
$V_{IHCMR}$	Input High Voltage Common Mode Range (Differential) (CLK, /CLK) $V_{PP} < 500mV$ $V_{PP} \geq 500mV$	<b>Note 6</b>	1.3 1.6		2.9 2.9	V V
$V_{BB}$	Output Reference Voltage		1.92		2.04	V
$I_{IH}$	Input HIGH Current				150	$\mu A$
$I_{IL}$	Input LOW Current (CLK, CLK_SEL, FSEL, MR) (/CLK)		0.5 -300			$\mu A$ $\mu A$

**Notes:**

1. Permanent device damage may occur if the ratings in "Absolute Maximum Ratings" section are exceeded. This is a stress rating only and functional operation is not implied at conditions other than those detailed in the operational sections of this data sheet. Exposure to absolute maximum ratings conditions for extended periods may affect device reliability.
2. The data sheet limits are not guaranteed if the device is operated beyond the operating ratings.
3. Due to the limited drive capability use for input of the same package only.
4. The circuit is designed to meet the DC specifications shown in the above table after thermal equilibrium has been established.
5. Input and output parameters are for  $V_{CC} = 3.3V$ . They vary 1:1 with  $V_{CC}$ .
6.  $V_{IHCMR}$  is defined as the range within which the  $V_{IH}$  level may vary with the device still meeting the propagation delay specification. The  $V_{IL}$  level must be such that the peak-to-peak voltage is less than 1.0V and then greater than or equal to  $V_{PP(min)}$ .

**LVECL DC ELECTRICAL CHARACTERISTICS<sup>(5)</sup>**

$V_{CC} = 0V$ ;  $V_{EE} = -3.3V \pm 0.3V$ ;  $T_A = -40^\circ C$  to  $+85^\circ C$ , typicals are  $T_A = 25^\circ C$ .

Symbol	Parameter	Condition	Min	Typ	Max	Units
$V_{OH}$	Output High Voltage	$R_L = 50\Omega$ to $V_{CC} - 2V$	-1085	-955	-880	mV
$V_{OL}$	Output Low Voltage	$R_L = 50\Omega$ to $V_{CC} - 2V$	-1830	-1705	-1620	mV
$V_{IH}$	Input High Voltage		-1165		-880	mV
$V_{IL}$	Input Low Voltage		-1810		-1475	mV
$V_{IIHCMR}$	Input High Voltage Common Mode Range (Differential) (CLK, /CLK) $V_{PP} < 500mV$ $V_{PP} \geq 500mV$	<b>Note 6</b>	-2.0 -1.7		-0.4 -0.4	V V
$V_{BB}$	Output Reference Voltage		-1.38		-1.26	V
$I_{IH}$	Input HIGH Current				150	$\mu A$
$I_{IL}$	Input LOW Current (CLK, CLK_SEL, FSEL, MR) (/CLK)		0.5 -300			$\mu A$ $\mu A$

**AC ELECTRICAL CHARACTERISTICS<sup>(7)</sup>**

$V_{CC} = +3.0$  to  $+3.6V$  and  $V_{EE} = 0V$  or  $V_{CC} = 0V$  and  $V_{EE} = -3.0$  to  $-3.6V$ ;  $T_A = -40^\circ C$  to  $+85^\circ C$ , typicals are  $T_A = 25^\circ C$ .

Symbol	Parameter	Condition	Min	Typ	Max	Units
$f_{MAX}$	Maximum Operating Frequency		1.2	>1.5		GHz
$t_{pd}$	Propagation Delay	IN (Differential), <b>Note 8</b> IN (Single-ended), <b>Note 9</b> MR	1040 1090 1000	1210 1335 1200	1420 1570 1520	ps ps ps
$t_{SKEW}$	Within-Device Skew	<b>Note 10</b>			50	ps
	Part-to-Part Skew (Differential)				300	ps
$t_{JITTER}$	Random Clock Jitter			< 1		ps <sub>RMS</sub>
$V_{PP}$	Differential Input Swing	<b>Note 11</b>	400		1000	mV
$t_r, t_f$	Output Rise/Fall Time (Q, /Q)	(20% to 80%)	200		600	ps

**Notes:**

- The circuit is designed to meet the DC specifications shown in the above table after thermal equilibrium has been established.
- $V_{IIHCMR}$  is defined as the range within which the  $V_{IH}$  level may vary with the device still meeting the propagation delay specification. The  $V_{IL}$  level must be such that the peak-to-peak voltage is less than 1.0V and then greater than or equal to  $V_{PP}(\min)$ .
- High-frequency AC parameters are guaranteed by design and characterization.
- The differential propagation delay is defined as the delay from the crossing points of the differential input signals to the crossing point of the differential output signals.
- The single-ended propagation delay is defined as the delay from the 50% point of the input signal to the 50% point of the output signal.
- The within-device skew is defined as the worst-case difference between any two similar delay paths within a single device.
- $V_{PP}(\min)$  is defined as the minimum input differential voltage, which will cause no increase in the propagation delay. The  $V_{PP}(\min)$  is AC limited for the SY100E222L as a differential input as low as 50 mV will still produce full ECL levels at the output.

**SINGLE-ENDED AND DIFFERENTIAL SWINGS**

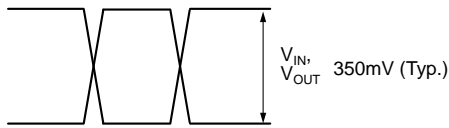

Figure 1a. Single-Ended Voltage Swing

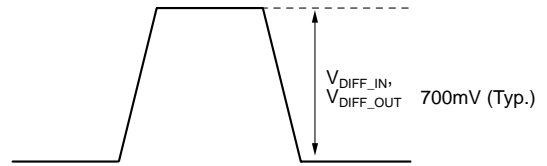
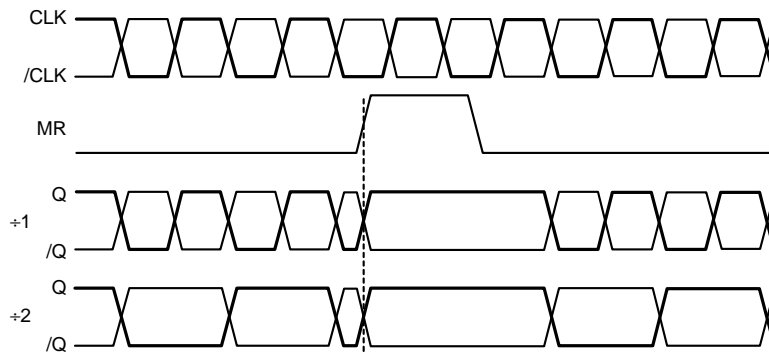

Figure 1b. Differential Voltage Swing

**TIMING DIAGRAM**



**TRUTH TABLE**

MR	CLK_SEL	FSEL	Q
0	0	0	CLK0 ÷ 1
0	0	1	CLK0 ÷ 2
0	1	0	CLK1 ÷ 1
0	1	1	CLK1 ÷ 2
1	X	X	0

**52-PIN LQFP (LQFP-52)**

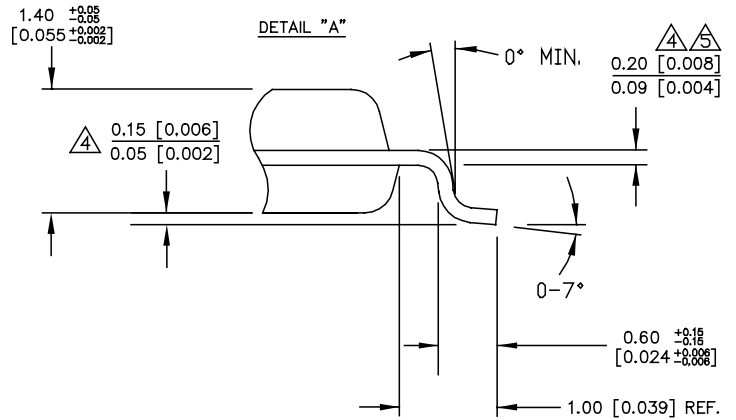
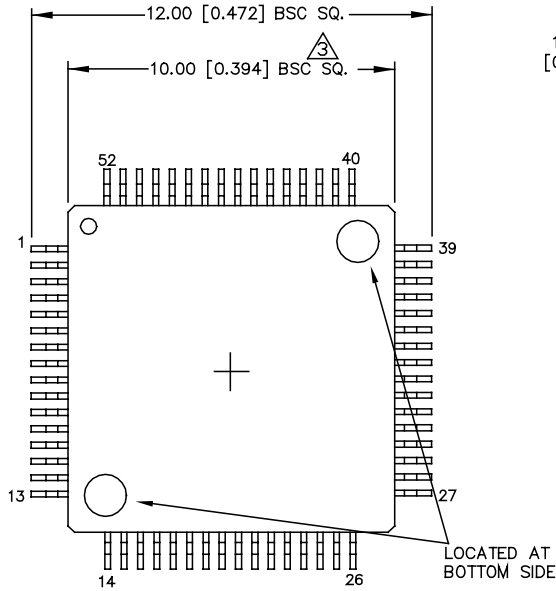

- NOTES:
1. DIMENSIONS ARE IN MM[INCHES].
  2. CONTROLLING DIMENSION: MM.
  3. DIMENSION DOES NOT INCLUDE MOLD FLASH OF 0.254[0.010] MAX.
  4. MAXIMUM AND MINIMUM SPECIFICATIONS ARE INDICATED AS FOLLOWS:  $\frac{\text{MAX}}{\text{MIN}}$
  5. THIS DIMENSION INCLUDES LEAD FINISH.

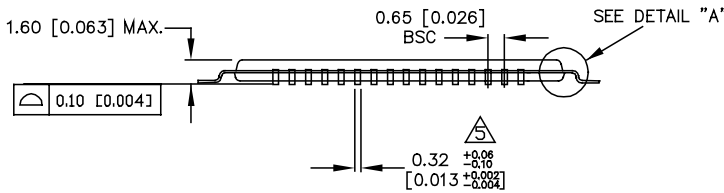

**MICREL, INC. 2180 FORTUNE DRIVE SAN JOSE, CA 95131 USA**

TEL + 1 (408) 944-0800 FAX + 1 (408) 474-1000 WEB <http://www.micrel.com>

The information furnished by Micrel in this data sheet is believed to be accurate and reliable. However, no responsibility is assumed by Micrel for its use. Micrel reserves the right to change circuitry and specifications at any time without notification to the customer.

Micrel Products are not designed or authorized for use as components in life support appliances, devices or systems where malfunction of a product can reasonably be expected to result in personal injury. Life support devices or systems are devices or systems that (a) are intended for surgical implant into the body or (b) support or sustain life, and whose failure to perform can be reasonably expected to result in a significant injury to the user. A Purchaser's use or sale of Micrel Products for use in life support appliances, devices or systems is at Purchaser's own risk and Purchaser agrees to fully indemnify Micrel for any damages resulting from such use or sale.

© 2005 Micrel, Incorporated.